

Tech Rim Standards

TR160 TECH-PIVOT



SEE BROCHURE FOR ORDERING INFORMATION

PIVOT TYPE	A (mm)	B (mm)	MASS (Kg)	MASS (lbs)	Cylinder Ports	Lock Port
TR160, LOCKING CYLINDER	430	543	260.0	573.0	3/4	1/4

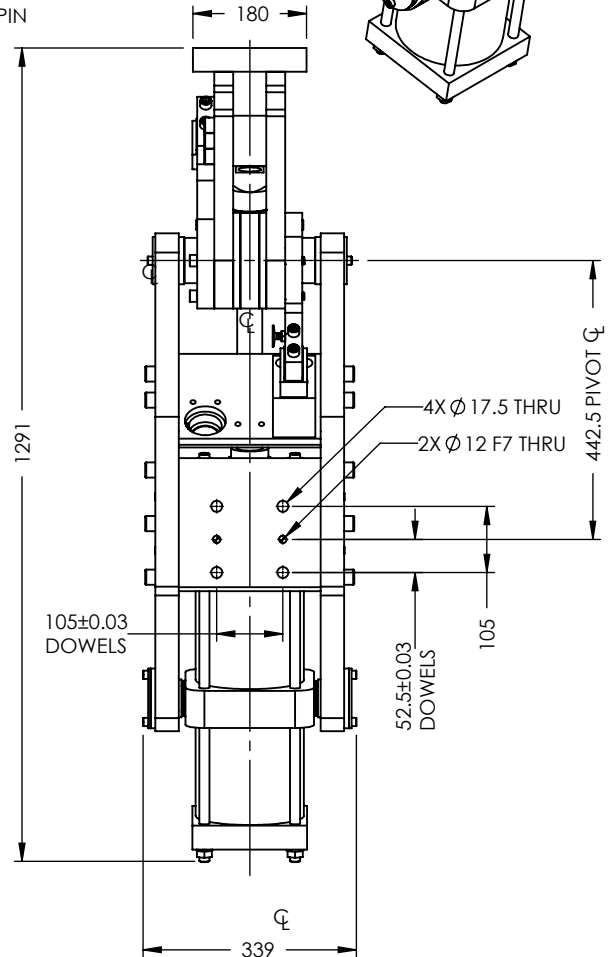
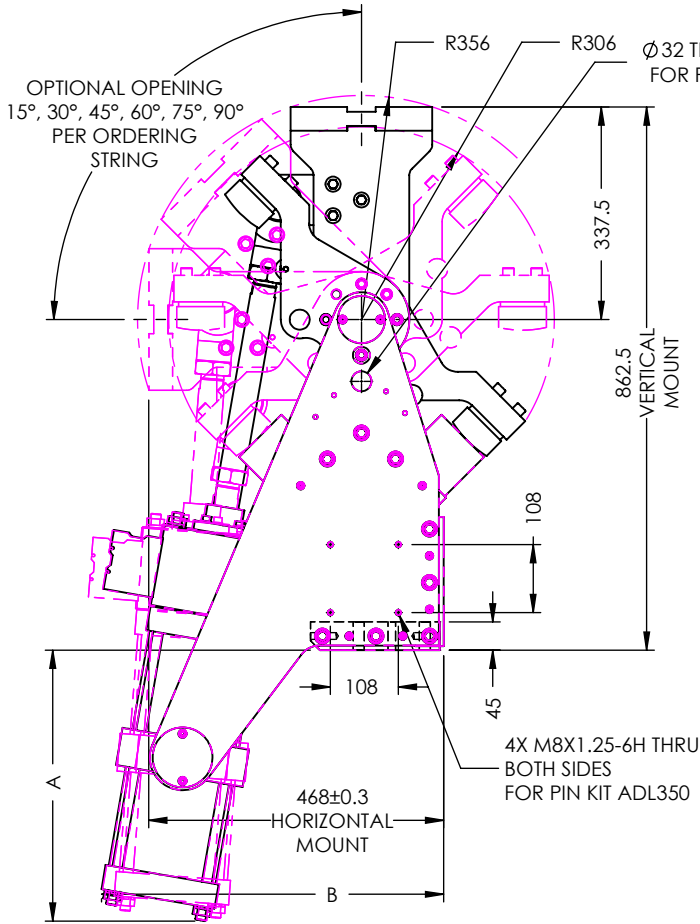
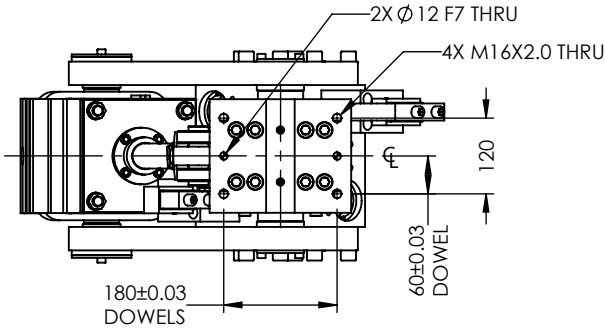
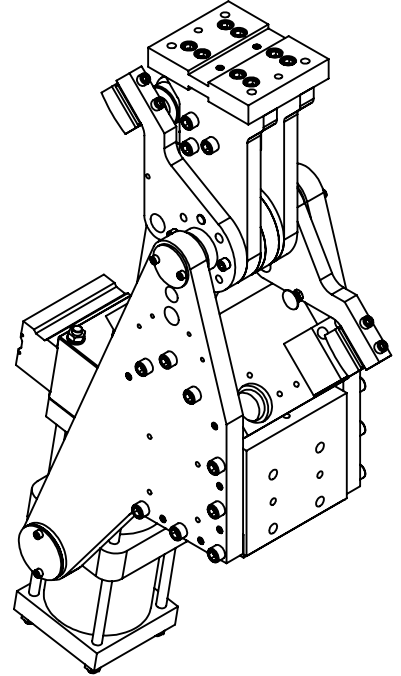

HORIZONTAL MOUNTING DIMENSIONS

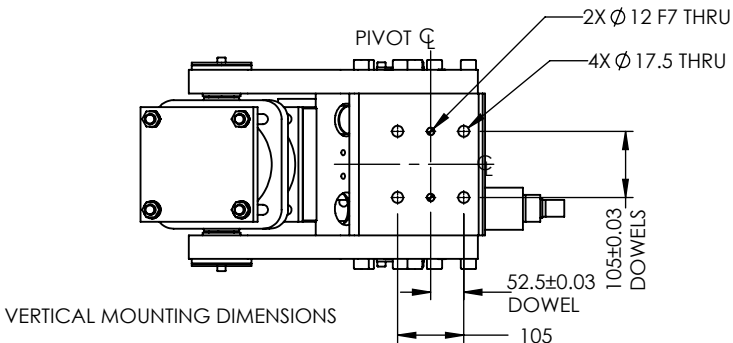

VERTICAL MOUNTING DIMENSIONS