

TECH-PIVOT: TR80/TR100/TR160

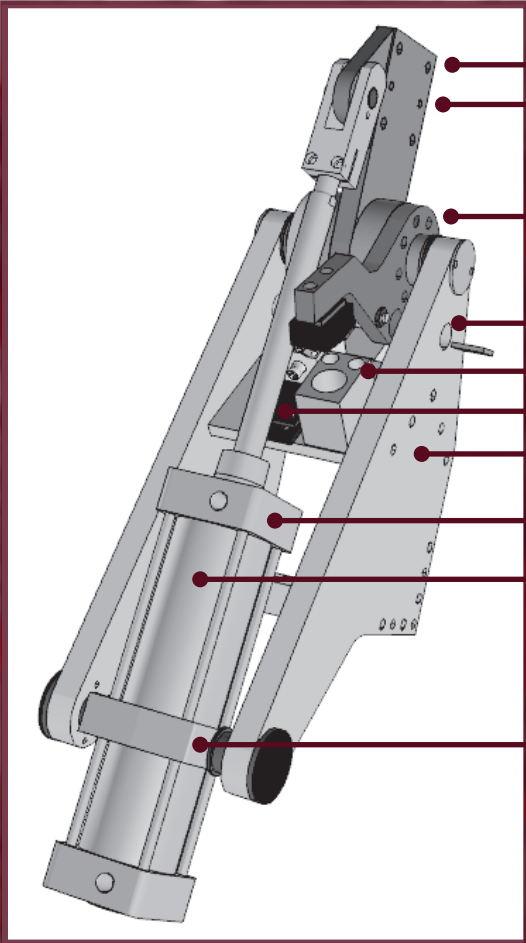

NAAMS Standard Hole Patterns
Tongue Mount

Fully adjustable opening angles in 15° increments

Lockout Pin Hole Access
Adjustable Integrated Shocks
Prox Switch Ready [Mounting]

Flexible/Compact Design

Internal Coil Scraper for Weld Debris Protection

One body size can accommodate both the 80 & 100mm bore cylinders: optimizing possible design changes

Variable Stroke Options

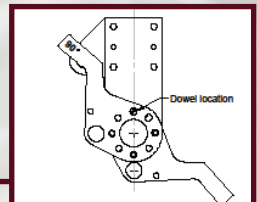
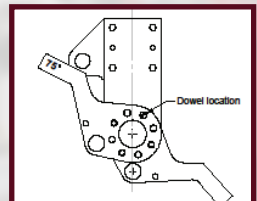
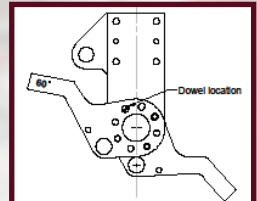
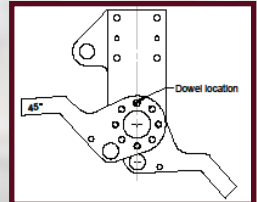
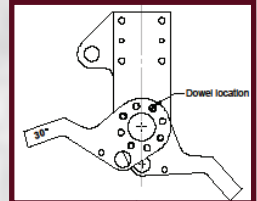
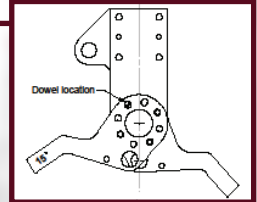

HD-FLEX MOUNT
A modular option for 'direct' horizontal mounting

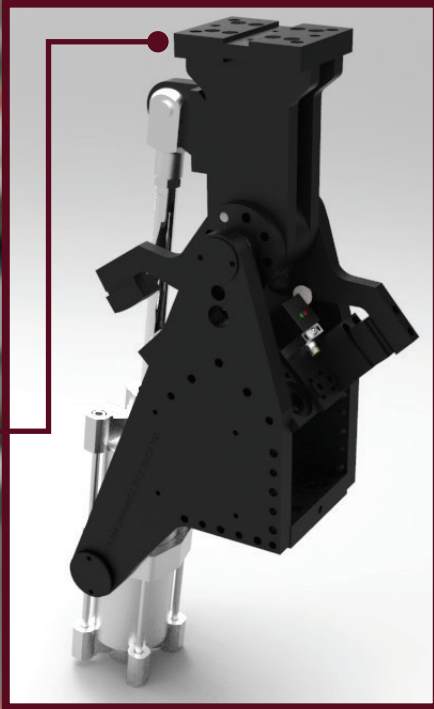

TOOLING WEIGHT CHARTS

TECH-PIVOT 80/100 (VERTICAL/HORIZONTAL)

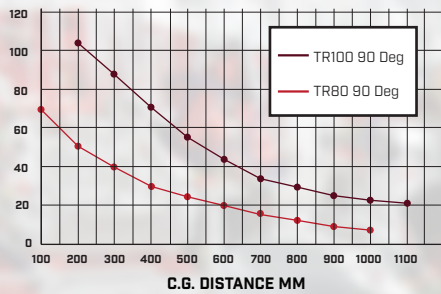

*Safe operating zone operating indicated below the curved line.

100mm Cylinder bore	65 psi	80 psi
Max. Push Force	3480 N	4300 N
Max. Pull Force	3300 N	4100 N
Cylinder Cycle Time	2 sec.	2 sec.

TECH-PIVOT 160 (VERTICAL/HORIZONTAL)

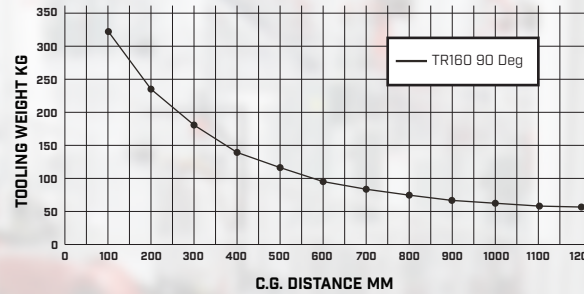

160mm Cylinder bore	80 psi	Unlocking Pressure	0.25MPa / +
Max. Push Force	11089 N	Locking Pressure	0.20MPa / -
Max. Pull Force	10395 N	Max. Op. Pressure	1.0MPa
		Holding Force	13.8 KN

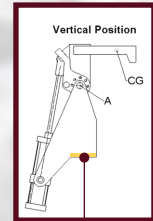

V - Mounting Plate

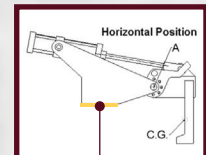

H - Mounting Plate

ORDERING INFORMATION

SAMPLE ORDER

Pivot Model	Body Mount	Opening Angle	Tool Mount	Cylinder	Switch	Shocks	Work Position	Mirror
TR80	V	90	4	1	P	E	R	*M

ACCESSORIES

Lockout Pin - ADL050
 Lockout Bracket - ADL051
 Lockout Pin Assembly - ADL070

PART # DETAILS

MODEL NUMBER TR80 - 80mm Cylinder
 TR100 - 100mm Cylinder
 TR160 - 160mm Cylinder

BODY MOUNT V - Vertical
 H - Horizontal

OPENING ANGLE 15°, 30°, 45°, 60°, 75° or 90° opening angle (default 90°)

TOOL MOUNT 4-Tongue (Vertical)
 6-HD (Flex Mount)*

* TR160 - Only available with 6-HD Tool Mount option.

80MM CYLINDER:
 1 - SMC 3/8" NPT Port
 2 - SMC 3/8" G Port
 3 - CKD 3/8" Npt Port
 4 - CKD 3/8" G Port
 L - Locking Cylinder
 Options Available (E.g.: 1L)

SWITCH for 40mm X 20mm
 Cube Style Prox Switch
 (Customer Supplies Switch/Sensor)

SHOCKS E - Enidine
 A - Ace
 H - Heavy Duty (only available on TR160)

WORK POSITION "R" retracted work position with cylinder retracted
 Leave blank for standard

100MM CYLINDER:
 1 SMC 1/2" NPT
 2 SMC 1/2" G
 3 CDK 1/2" NPT
 4 CDK 1/2" G
 L - Locking Cylinder
 Options Available (E.g.: 1L)

*M

160MM CYLINDER:
 1L SMC 3/4" NPT port locking head
 2L SMC 3/4" G port locking head
 3L CKD 3/4" NPT port locking head
 4L CKD 3/4" G port locking head

In a shown & opposite application:
 The arm mounted in an "opposite callout" is designated by "M" (mirror)