

TE-RDN-40, TOOLING RECEIVER

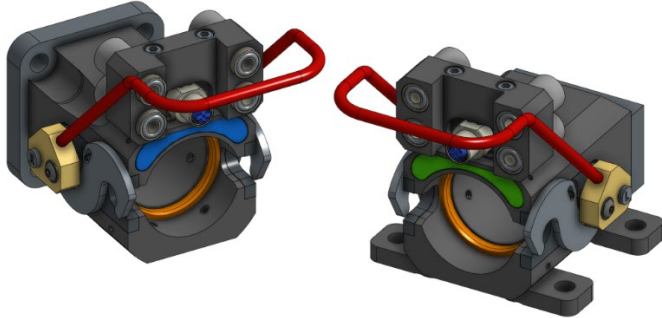

The TE-RDN-40 Tooling Receiver is an industry standard modular tool changer for industrial pressroom and robotic automation applications. Allows quick change-over between jobs. Air and electrical connections are optional for automatic coupling with the tooling adapter. There are many additional options available to easily integrate into new or existing tri-axis, crossbar or robotic automation.

Features

- Plug and Play compatibility
- Quick change-over for tooling branches
- Pneumatic & Electric Options
- Mount Options, Base and Flange
- Mechanical Coding and Color Options

Technical Overview

Item Weight	1.5-2.0 kg, [3.2- 4.2lbs], depending on options
Overall Dimensions	112 x 118 x 115 mm [4.4 x 4.6 x 4.5 inches]
Operating Pressure	Vacuum to 6 bar [-12.7-87 psi]
Operating Voltage	10-30 vdc typical

Ordering Information

Ordering Information

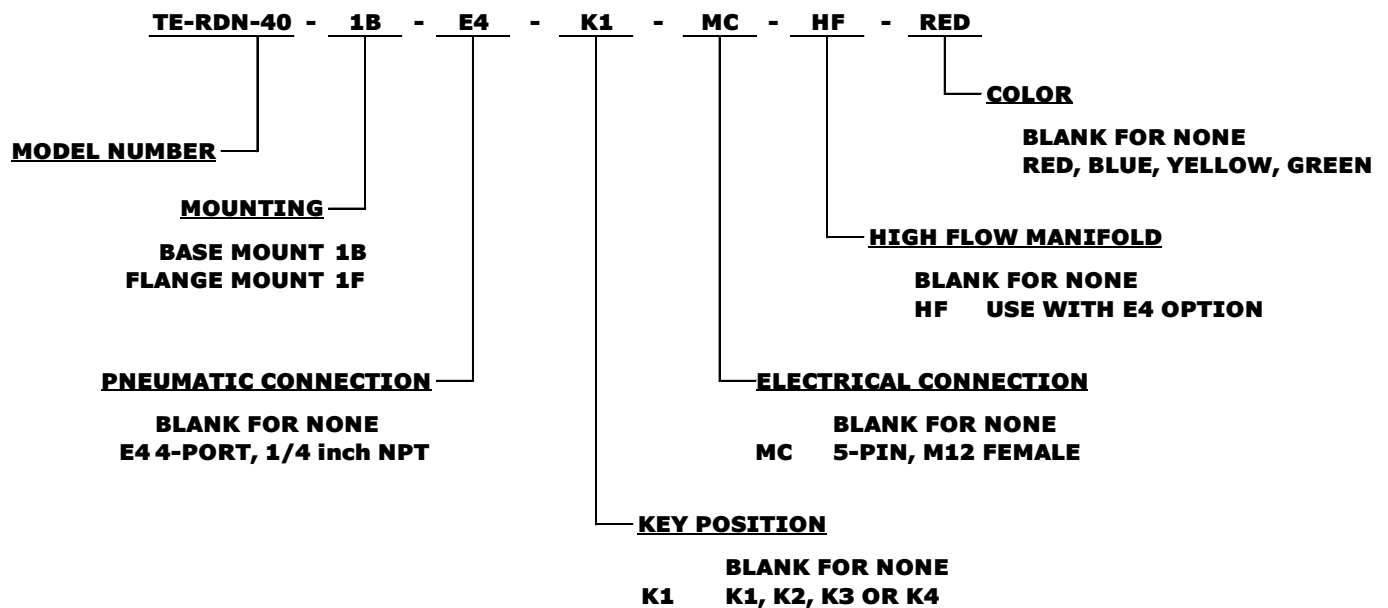

- Contact Tech Rim for additional options